



**Kiwa Nederland B.V.**

Sir Winston Churchillaan 273  
Postbus 70  
2280 AB RIJSWIJK

Tel. +31 88 998 44 00  
Fax +31 88 998 44 20  
[Eota@kiwa.nl](mailto:Eota@kiwa.nl)



Member of



[www.eota.eu](http://www.eota.eu)

## European Technical Assessment

**ETA-26/0223**  
of 20-04-2026

### General Part

**Technical Assessment Body issuing the European Technical Assessment:**

Kiwa Nederland B.V.

**Trade name of the construction product**

**Plastic cable chambers made of polycarbonate (polycarbonate plastic chamber)**

**Product family to which the construction product belongs**

Plastic chambers for underground network access applications installed below manhole tops

PAC: 34

**Manufacturer**

Langmatz GmbH  
Am Gschwend 10  
82467 Garmisch-Partenkirchen, Germany

**Manufacturing plant(s)**

Langmatz GmbH  
Alte Ettaler Straße 10  
82496 Oberau, Germany

**This European Technical Assessment contains**

14 pages including 1 Annex(es) which form an integral part of this assessment

**This European Technical Assessment is issued in accordance with Article 95(4) of Regulation (EU) No 2024/3110, on the basis of:**

EAD 340225-00-1109  
Plastic chambers for underground network access applications installed below manhole tops

Translations of this European Technical Assessment in other languages shall fully correspond to the original issued document and should be identified as such.

Communication of this European Technical Assessment, including transmission by electronic means, shall be in full (excepted the confidential Annex(es) referred to above). However, partial reproduction may be made, with the written consent of the issuing Technical Assessment Body. Any partial reproduction has to be identified as such.

## Specific parts

### 1. Technical description of the product

#### 1.1. General

The Plastic cable chambers made of polycarbonate (polycarbonate plastic chamber) is a plastic chamber system for underground network access applications installed below manhole tops.

The chamber systems are rectangular with the open widths of 600 mm or 1 200 mm and a maximum height of ca. 1 200 mm.

The chamber systems are made of profiled structurally foamed polycarbonate frame elements that are manufactured via thermoplastic foam injection moulding. The frame elements contain prefabricated recesses and predetermined sections for cable entry points. Those entry points need to be opened up at location. The frame elements are installed horizontally and connected to form frame. Multiple frames are stacked together to form the chamber system.

The lowest frame can be installed in a rotated position with the help of universal connectors.

The chamber system consists of the following components:

**Table 1.1.1 Components of the chamber system**

Nr.	Component	Figure
1	Frame element "EK1000/1" (LW 600)	Figure 3
2	Frame element "EK 1000/2" (LW 1200)	Figure 4
3	Universal frame connector "EK 1005/1"	Figure 5
4	Base plate "EK1004"	Figure 6
5	Corner adapter for base plate "EK 1005/5"	Figure 7

#### 1.2. Description of the components

##### 1.2.1. Frame elements

The frame elements "EK1000/1" and "EK 1000/2" are made from the material "Polycarbonat GF6" (PC GF6).

The dimensions are given in Figure 3 and Figure 4.

##### 1.2.2. Universal connector

The universal connector "EK 1005/1" is required when a frame will be installed rotated. The universal connector is made of polycarbonate.

The dimensions are given in Figure 5.

##### 1.2.3. Frame

The frames are made of frame elements in accordance with clause 1.2.1. The frames have a height of 250 mm and come in the following variations:

**Table 2.2.3.1 Available dimensions of the chamber system**

		Frame length (open length)	
		600 mm	1 200 mm
Frame width (open width)	600 mm	available	available
	1 200 mm	not available	

Following conditions shall be observed:

- the frame is a rectangle
- the sides of the frame with the open width of 600 mm and 1 200 mm consist of a single frame element

#### **1.2.4. Base plate (optional)**

The installation of the base plate “EK1004” is optional. It is made of either PP, PC PE or ABS.

The dimensions are given in Figure 6.

#### **1.2.5. Corner adapter for base plate**

In case of installation of a base plate, the use of the corner adapter “EK 1005/5” is mandatory. Four corner adapters shall be used for the installation of a base plate. The corner adapter is made of polycarbonate.

The dimensions are given in Figure 7.

### **1.3. Description of the chamber system**

The chamber system consists of frames in accordance with clause 1.2.3. Optionally, a base plate in accordance with clause 1.2.4 can be installed with the use of corner adapters in accordance with clause 1.2.5.

The chamber systems are distinguished in accordance with their open dimensions:

open length [mm] x open width [mm] x total height [mm]

The maximum height of the chamber system (including the height of the cover) is ca. 1 200 mm. The cover shall be installed on top of the chamber system and conform to EN 124.

Installation diagrams are given in Figure 1 and Figure 2.

## **2. Specification of the intended use(s) in accordance with the applicable European Assessment Document (hereinafter EAD)**

### **2.1. Intended use**

The chamber system is intended for use in conjunction with jointing, feeding through and branching cables, pipes or ducts and the housing of active and passive technical components. They can be used in all accessible (by foot and vehicle) areas such as parking areas, pedestrian zones, sidewalks and hard shoulders, along roads and rail tracks as well as in road surfaces and lanes.

### **2.2. Assumed working life**

The provisions made in this ETA are based on an assumed working life of 25 years, provided that:

- the product is properly designed and built,
- installation of product is performed as per installation guide, under normal site conditions, by adequately trained installers,
- minor damages are repaired (for example damage caused by impact),
- the product is properly used and maintained.

These provisions are based upon the current technological state of the art and the available knowledge and experience.

In normal use conditions, the real working life may be considerably longer without major degradation affecting the basic requirements for construction works<sup>1</sup>.

The indications given on the working life cannot be interpreted as a guarantee given by the producer, but are to be regarded as a means for choosing the right product in relation to the reasonable expected working life of the product.

### **2.3. Manufacturing**

The product is manufactured in accordance with the provisions of the European Technical Assessment using the manufacturing process as laid down in the technical file. It is the responsibility of the manufacturer to ensure that all necessary information on design and installation is submitted to those responsible for design and execution of the construction.

### **2.4. Packaging, transport and storage**

The product shall be packed, transported and stored in accordance to the manufacturer's technical documentation to prevent damages or deterioration. Damaged products should not be used. It is the responsibility of the manufacturer that adequate information is clearly shown on the package and/or enclosed instruction sheet.

### **2.5. Design and installation**

For the product the following shall be observed:

- The conditions for design and execution of the product into the works shall be taken from the manufacturer's technical documentation.
- Installation and handling shall be carried out by qualified employees and according to the manufacturer's technical documentation.
- The conditions set out in clauses 1.2 and 1.3 shall be observed.

### **2.6. Maintenance and repair**

The conditions for maintenance and repair shall be taken from the manufacturer's technical documentation.

---

<sup>1</sup> The real working life of a product incorporated in a specific works depends on the environmental conditions to which that works are subject, as well as on the particular conditions of design, execution, use, and maintenance of that works. Therefore, it cannot be excluded that in certain cases the real working life of the product may also be shorter than the assumed working life.

### 3. Performance of the product and references to the methods used for its assessment

**Table 3.1** *Essential characteristics of the product*

Essential characteristic	Performance
Mechanical resistance	
Impact strength	99,6 kJ/m <sup>2</sup>
Flexural strength	101 MPa
Elongation at bending strength	5,8 %
Tensile strength	66,5 MPa
Moisture absorption	0,073 %
Mechanical resistance after thermal stress	
Reduction of impact strength	≤ 8%
Reduction of flexural strength	≤ 8%
Reduction of elongation at bending strength	≤ 7%
Reduction of tensile strength	≤ 8%
Load-bearing capacity	No performance assessed
Shear stress testing	No performance assessed
Load-bearing capacity when installed	
Load case I	no indication of a failure that might influence the load bearing capacity of the system reduction of clearance ≤ 5 %
Load case II	no indication of a failure that might influence the load bearing capacity of the system Load class C 250
Load case III	Failure force ≥ 350 kN
Dynamic stress when installed	No performance assessed
Reaction to fire	No performance assessed
Release of particles during operation	0 (assessed without need for testing)

Chemical resistance	
Reduction of impact strength	≤ 7%
Reduction of flexural strength	≤ 7%
Reduction of elongation at bending strength	≤ 7%
Reduction of tensile strength	≤ 7%
UV resistance	
Reduction of impact strength	≤ 8%
Reduction of flexural strength	≤ 8%
Reduction of elongation at bending strength	≤ 7%
Reduction of tensile strength	≤ 8%

**4. Assessment and verification of constancy of performance (hereinafter AVCP) system applied, with reference to its legal base**

According to the decision 2015/1959/EC(EU) of the European Commission the system of assessment and verification of constancy of performance are as follows:

Intended use	Level(s) or class(es)	System
Any use except uses subject to regulations on reaction to fire	Any	4

**5. Technical details necessary for the implementation of the AVCP system, as provided for in the applicable EAD**

This ETA is issued for Plastic cable chambers made of polycarbonate (polycarbonate plastic chamber) on the basis of data/information deposited at Kiwa Nederland B.V. which identifies the product that has been assessed.

Changes to the product/production process, which could result in this deposited data/ information being incorrect, should be notified to the approval body before the changes are introduced. Kiwa Nederland B.V. will decide whether such changes affect the ETA and if so whether further assessment or alterations to the ETA shall be necessary.

Technical details necessary for the implementation of the AVCP system are laid down in the control plan, in accordance with Section 3.2 of EAD 340225-00-1109.

The control plan shall be handed over by the manufacturer to the notified body (bodies) involved in the assessment and verification of constancy of performance.

The tasks of the notified body are laid down in Section 3.3 of EAD 340225-00-1109.

Issued in Rijswijk on 20-04-2026 By



Wim van Loon  
Managing Director Nederland  
Kiwa Nederland B.V.

Annex A

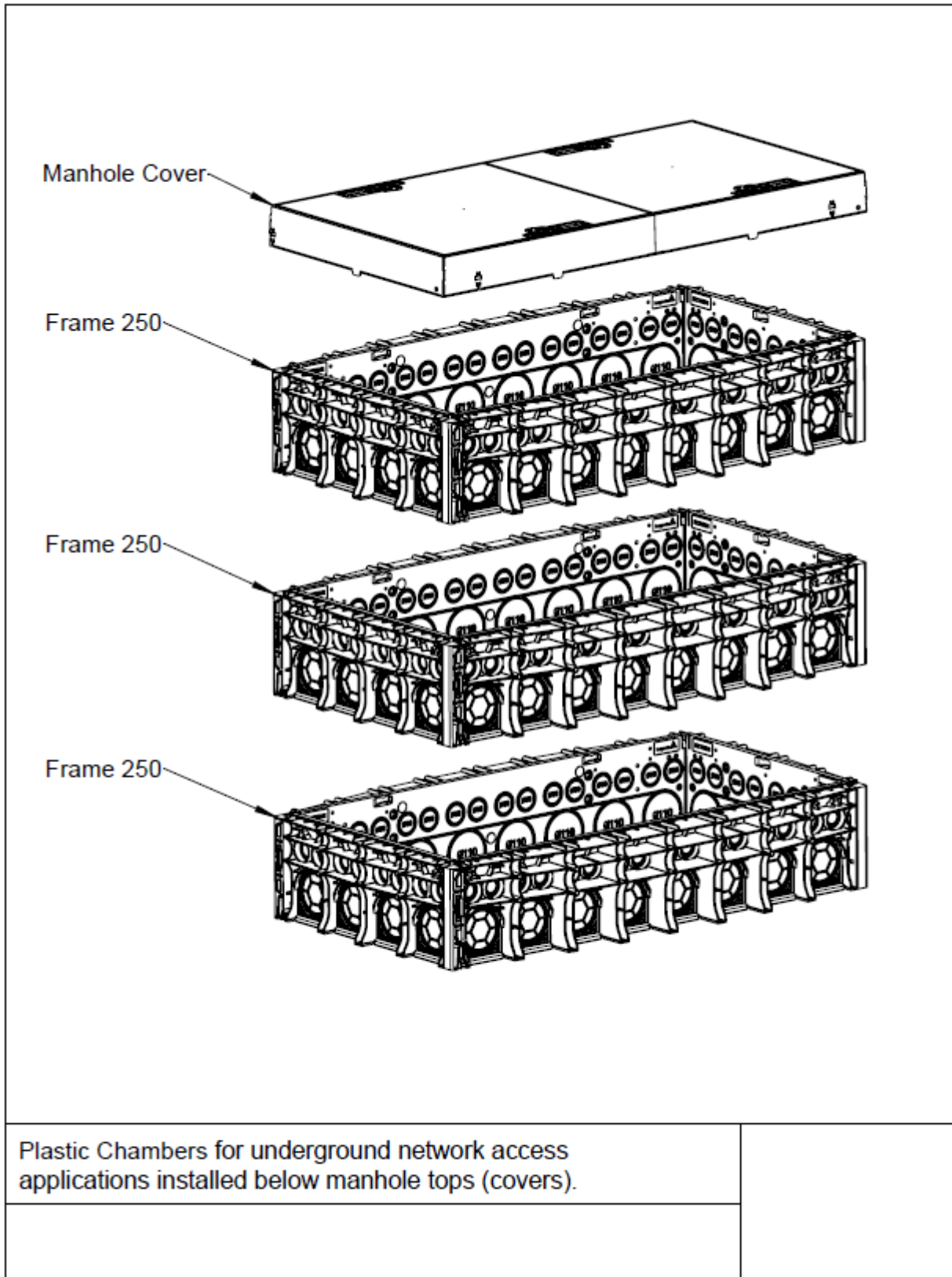

Figure 1 Installation diagram

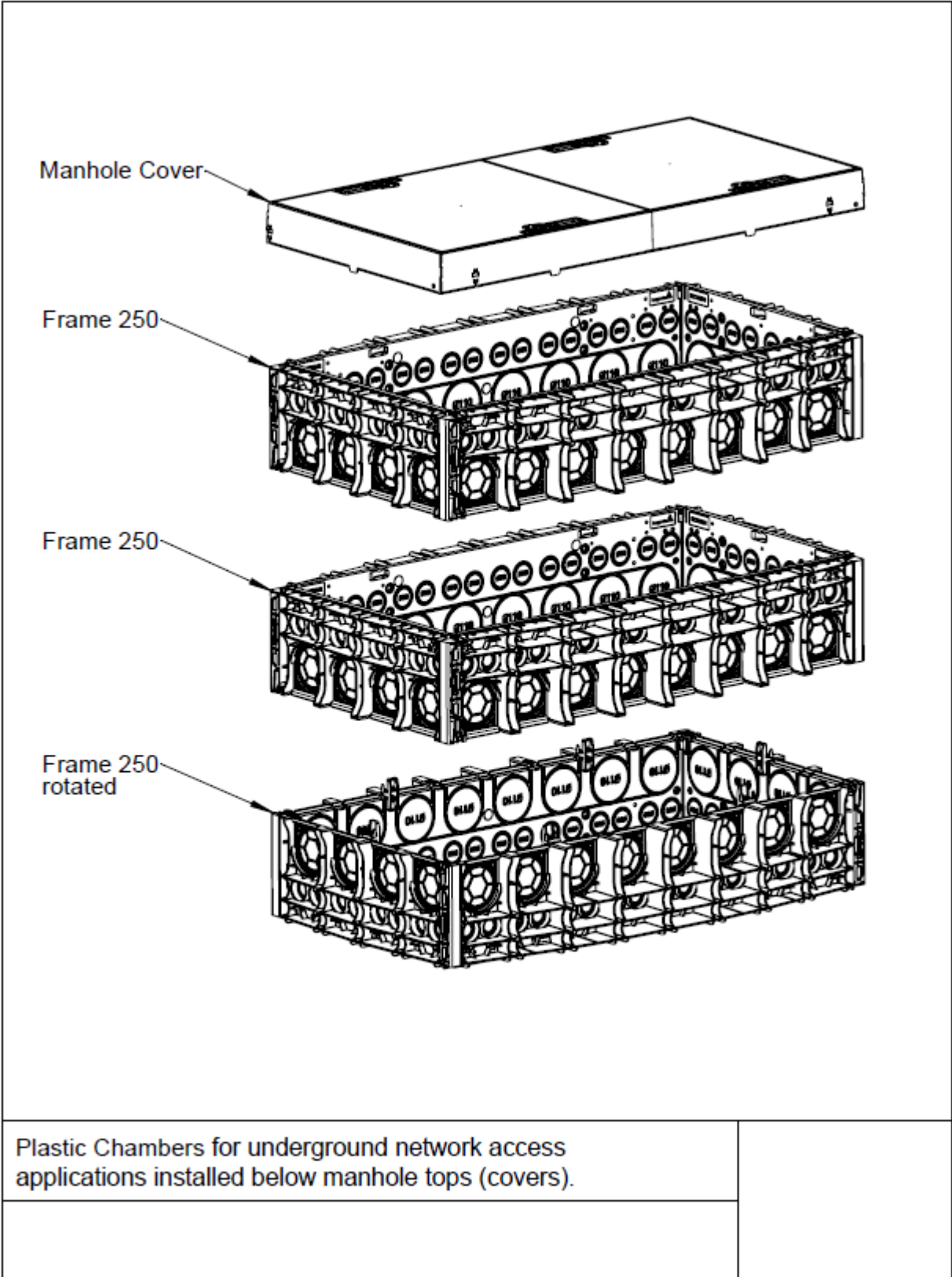

Figure 2 Installation diagram (rotated frame)

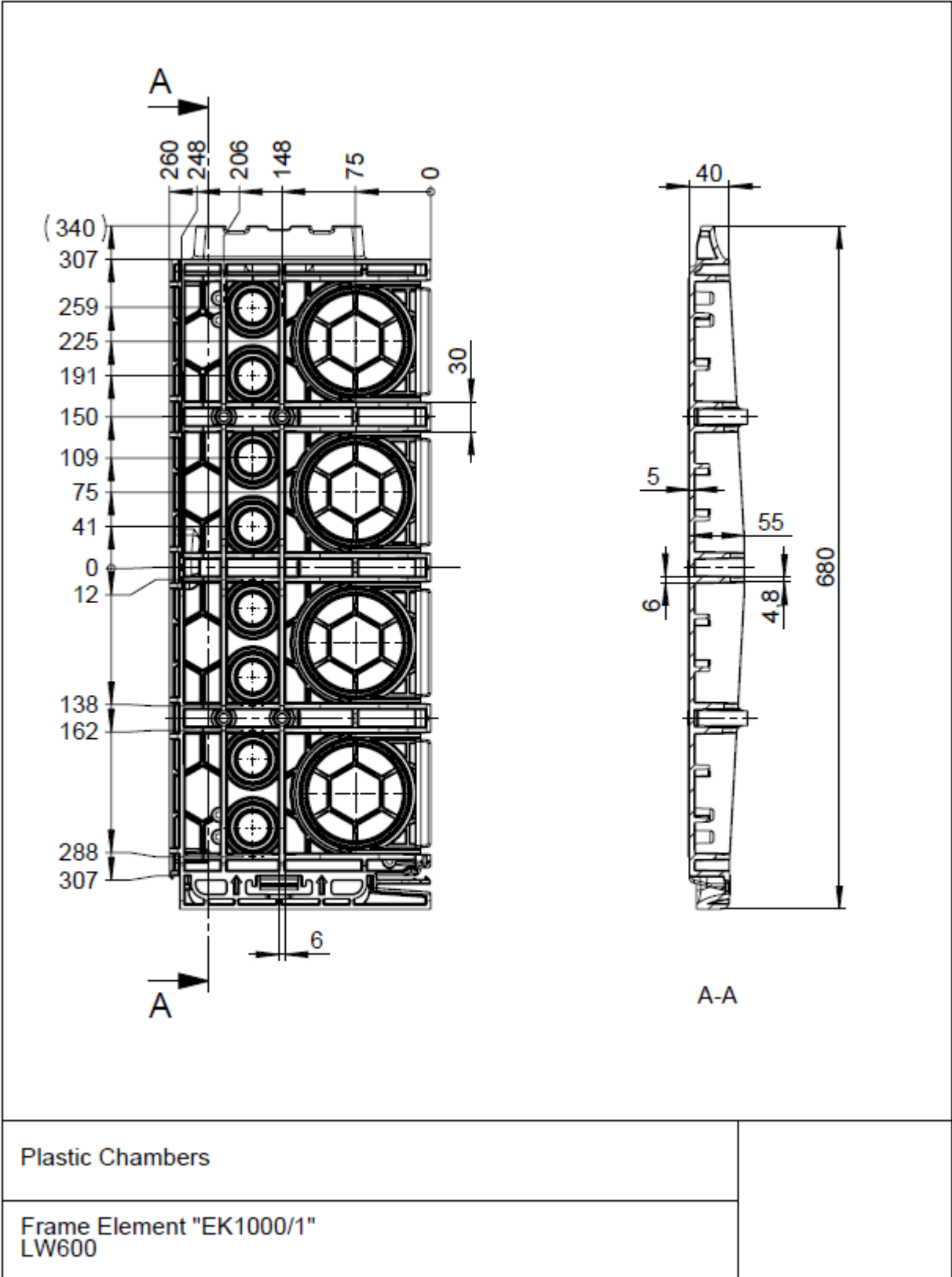

Figure 3 Frame element "EK1000/1"

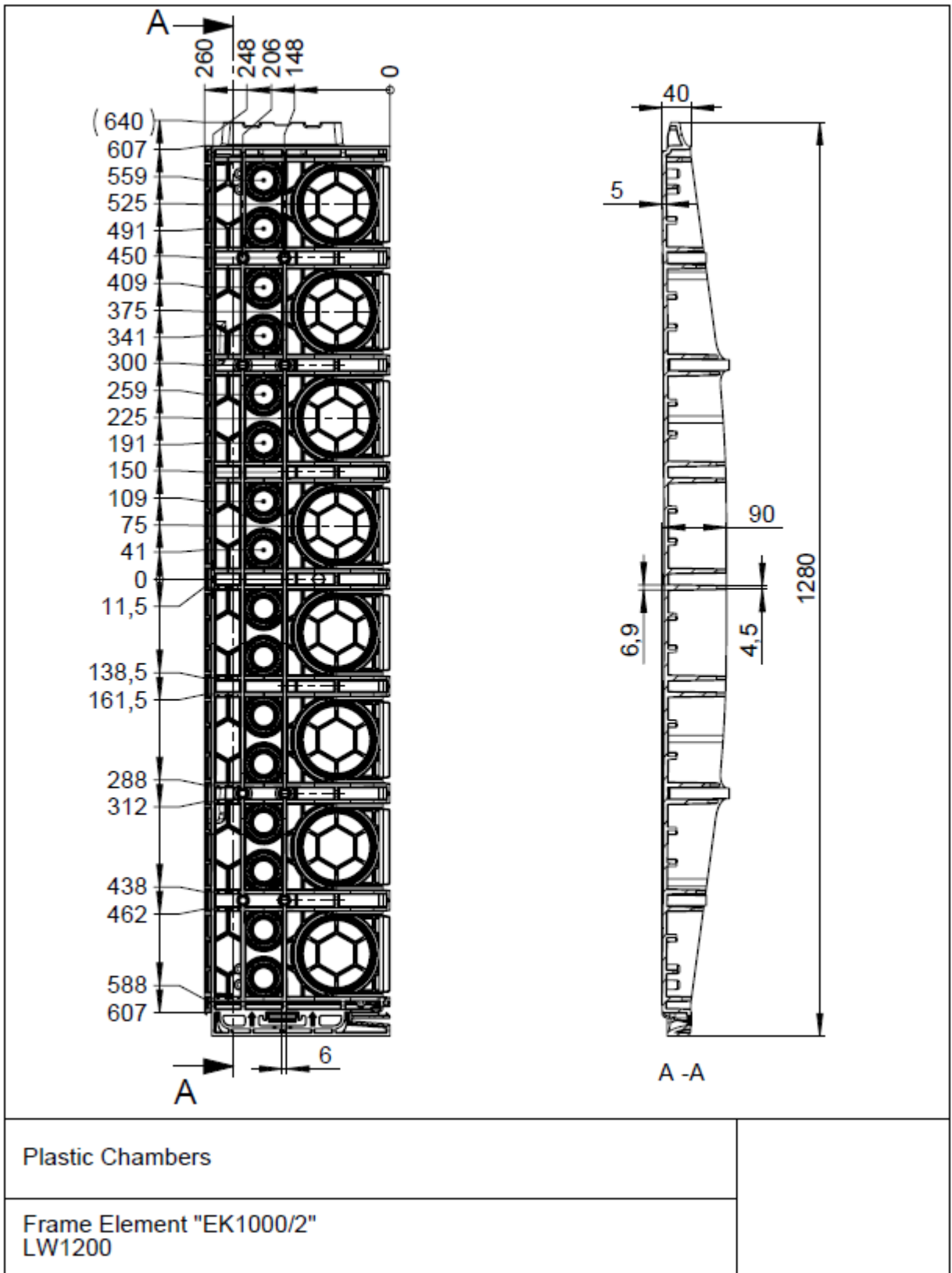
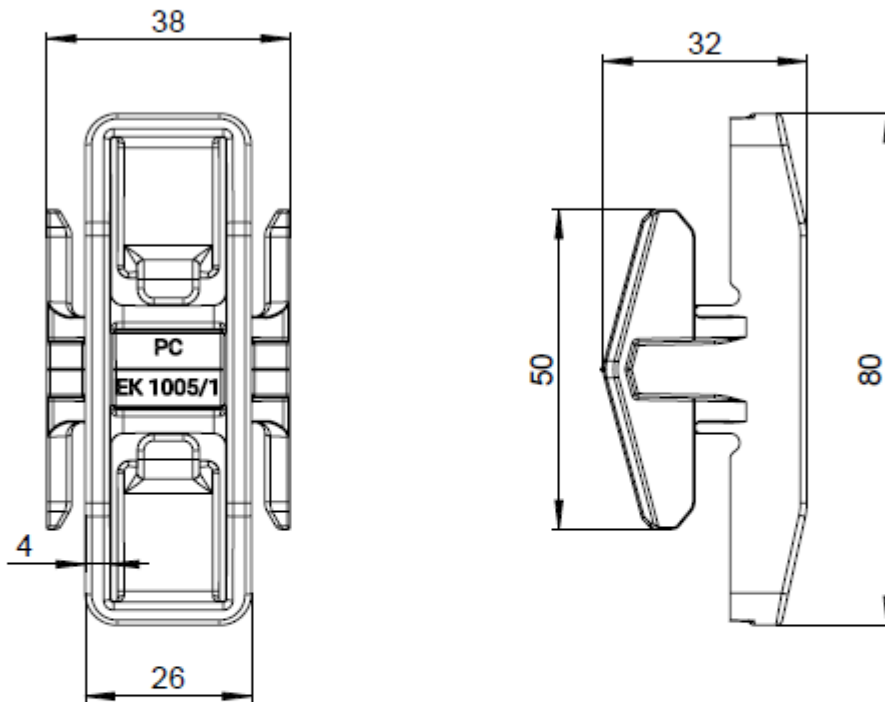

Figure 4 Frame element "EK 1000/2"



plastic chambers

universal frame connector  
EK1005/1

Figure 5 Universal connector "EK 1005/1"

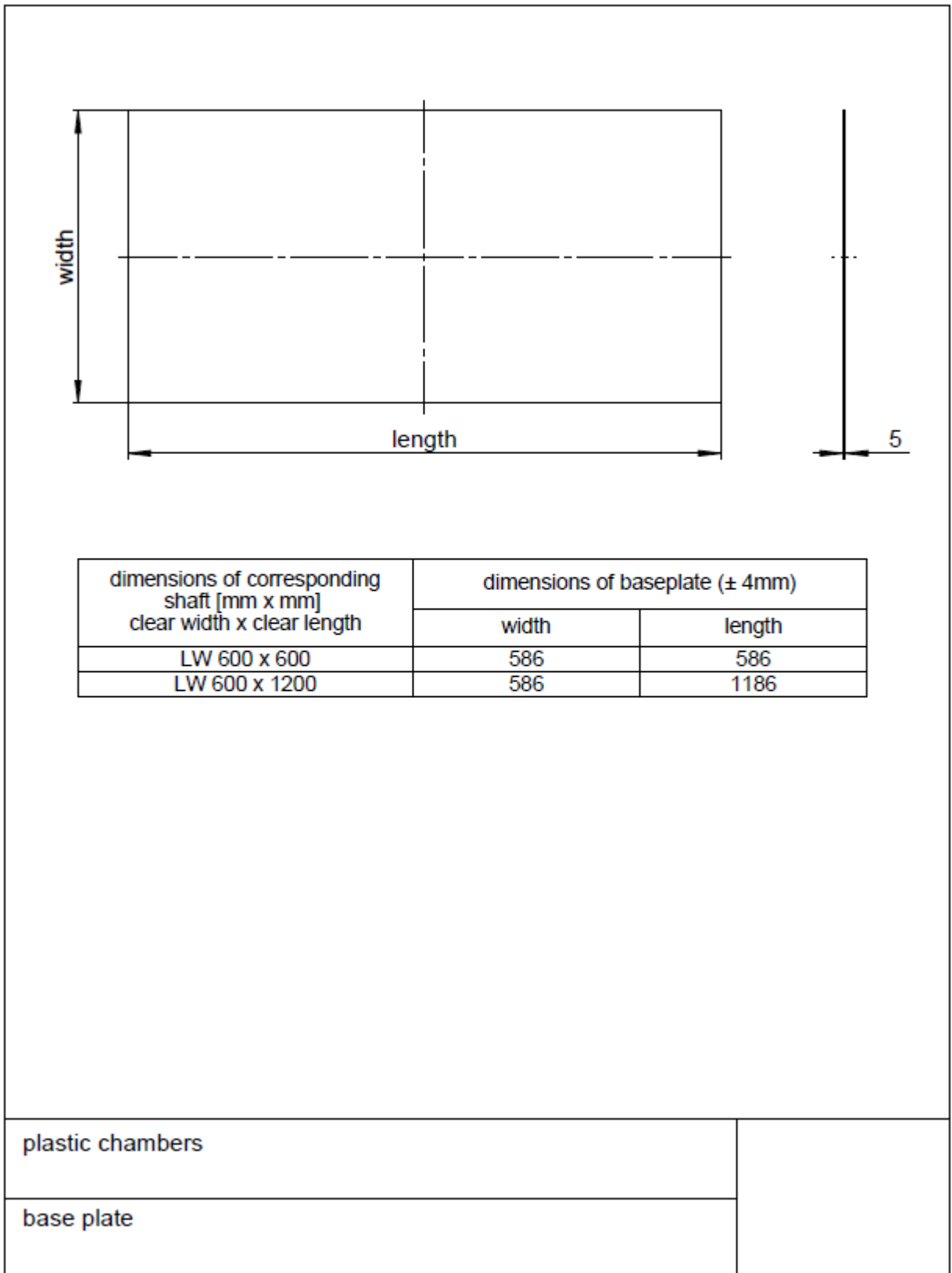

Figure 6 Base plate "EK1004"

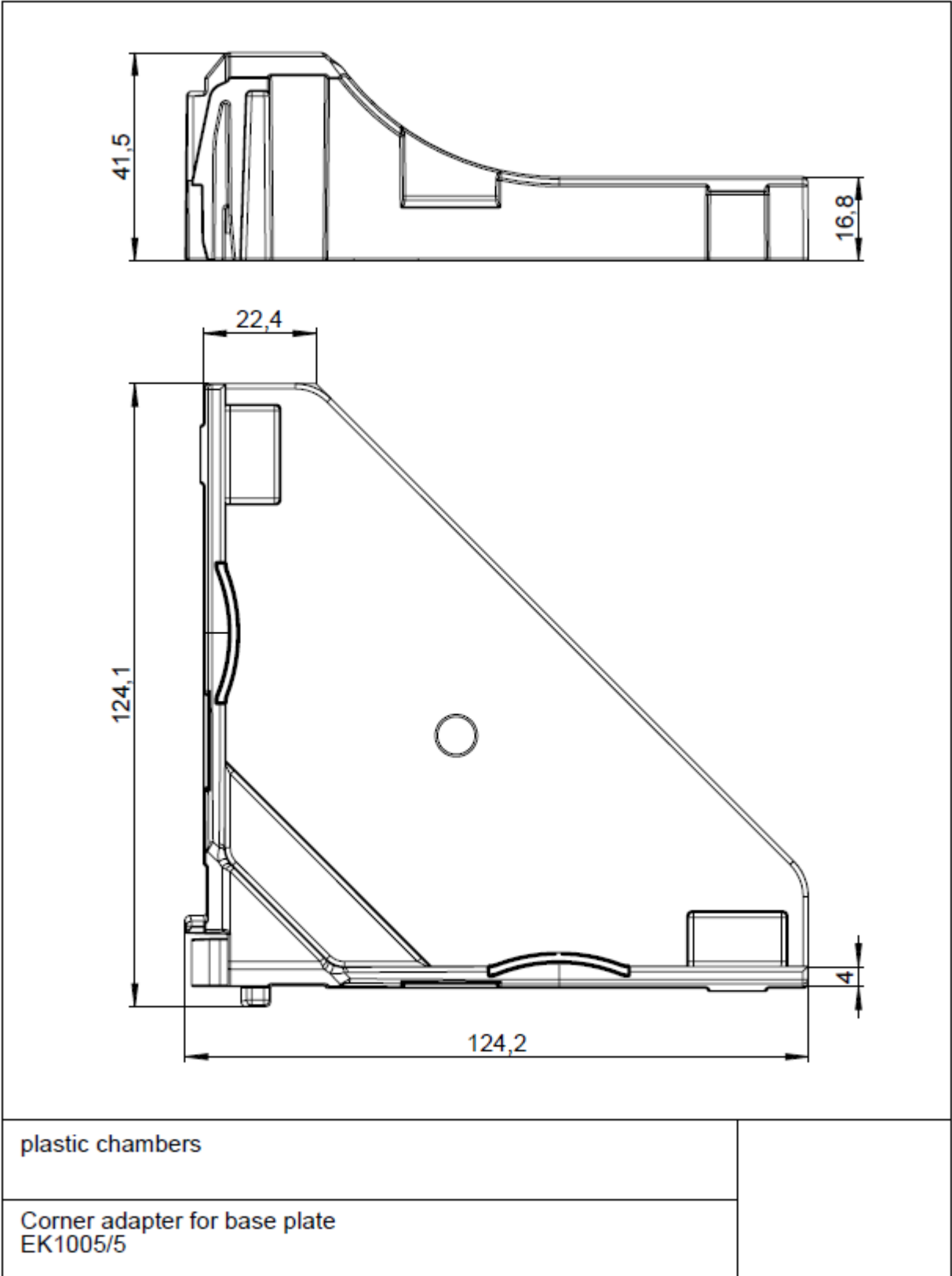

Figure 7 Corner adapter for base plate "EK 1005/5"